

# AIRPORT CONSTRUCTION CASTINGS



As of this writing, airport construction castings should be selected to sustain the loading requirements of a Boeing 727-200 and Lockheed L1011-500 aircraft. Although not the heaviest aircraft, load concentrations on these gear configurations currently represent the most severe loads exerted upon castings in a commercial airfield setting.

For heavier, dual-gear aircraft, an assumed spacing of 34" between the centerline of the tires has been considered reasonable by the FAA. The Boeing 727-200 (see Figure 1) is considered because the spacing of the wheels is such that 2 wheels may be concentrated on one casting. Based on this assumption, construction castings with clear openings greater than 34" can be subjected to loadings greater than that of one wheel. However, due to the distribution of this loading on the casting, the effective loading may not necessarily be as critical as a single concentrated wheel load in the center of the casting.

Notes to project designer:

**THE REFERENCES TO AIRCRAFT AND TO FAA MATERIALS CONTAINED ON THIS PAGE ARE CURRENT AS OF THIS WRITING, BUT MAY NOT BE CURRENT WHEN YOU READ THIS CATALOG. ALWAYS CHECK WITH THE FAA OR A QUALIFIED EXPERT TO ENSURE YOU ARE WORKING WITH UP-TO-DATE INFORMATION.**

--All items shown in Neenah's Airport Series are capable of withstanding minimum 100,000-pound loads as called for in FAA Advisory Circular AC 150/5320-6D Appendix 3 Item 2.d. (1).

--All items shown in Neenah's Airport Series will be furnished with covers or grates fastened to frames as called for in FAA Advisory Circular AC 150/5370-10A.

--All items shown in Neenah's Airport Series will be furnished unpainted per FAA Advisory Circular AC 150/5370-10A.

--Slotted vane drain (R-3599-B) is furnished per FAA Advisory Circular AC 150/5370-10A

Military installations, container ports and industrial applications may have aircraft or equipment exerting heavier loads than those expected on commercial airports. The product designer must determine tire pressure, contact area and wheel spacing information for each such application, after which Neenah Product Engineering will be glad to provide the designer with product information to assist in the selection of appropriate castings.

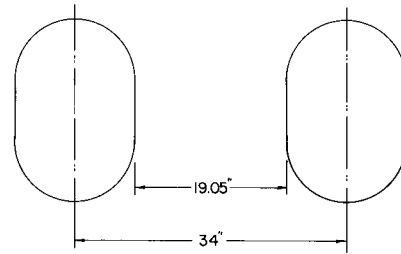

**Figure 1**  
**Boeing 727-200 Gear Configuration**  
**Contact Area 290 Sq. In. - Tire Pressure 167 psi**

Aircraft	Wheels Per Strut	Vehicle Main Gear* Pounds	Max. Load Per-Tire Pounds
727-100	2	76,900	34,450
727-200 STD	2	79,900	39,950
727-200 ADV	2	96,800	48,400
737-300	2	62,200	31,100
737-400	2	70,600	35,300
737-500	2	61,800	30,900
737-700	2	71,500	35,750
737-800	2	82,100	41,050
737-900	2	84,300	42,150
L1011-100	4	204,120	51,030
L1011-500	4	230,000	57,500
747-100B/300	4	174,000	43,500
747-400F	4	204,600	51,150
757-300	4	125,500	31,375
767-200ER	4	180,000	45,000
767-300ER	4	188,200	47,050
777	6	297,500	49,583
DC-10-10	4	212,535	53,134
DC-10-40	4	210,532	52,633
MD-11	4	242,000	60,500
MD-80-83	2	76,280	38,140
MD-90-30	2	75,740	37,870
A380	6	353,475	58,912
	4	235,650	58,912
A380F	6	372,025	62,004
	4	248,025	62,006

\* Maximum static load per strut at the most aft center of gravity.

■ Note: When specifying/ordering grates, refer to "Choosing the proper inlet grate" on pages 117-118.  
 For a complete listing of FREE OPEN AREAS and WEIR PERIMETERS of all NEENAH grates, refer to pages 306-311.

**R-3475**  
**Airport Drainage Inlet Frame, Deep Vertical Bar Grate**

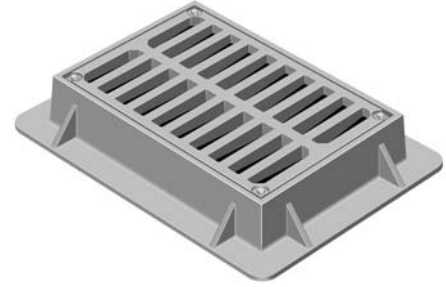
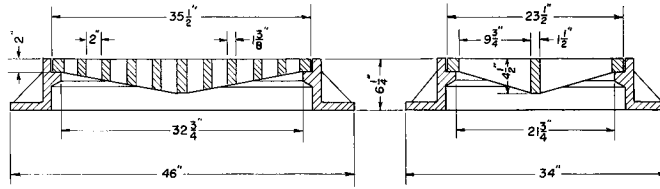

*Grates are bolted to frames.*

CATALOG NUMBER	GRATE TYPE	SQ. FT. OPEN	WEIR PERIMETER LINEAL FEET
R-3475	A	2.7	9.8

Also available with special Type C solid cover.  
 Also available with 3 1/2" adjusting frame.

**R-3475-3**  
**Airport Drainage Inlet Frame, Double Grate**

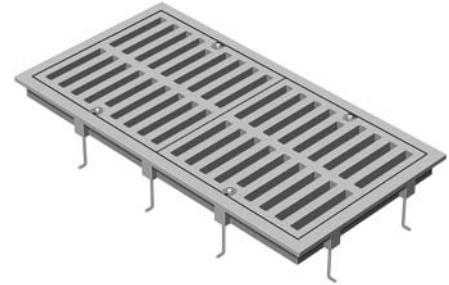
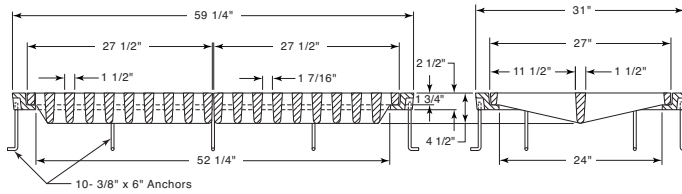

*Grates are bolted to frames.*

CATALOG NUMBER	GRATE TYPE	SQ. FT. OPEN	WEIR PERIMETER LINEAL FEET
R-3475-3	A	4.1	13.7

**R-3475-A**  
**Airport Drainage Inlet Frame, Deep Vertical Bar Grate**

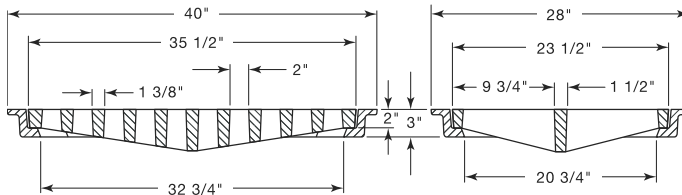

*Grates are bolted to frames.*

CATALOG NUMBER	GRATE TYPE	SQ. FT. OPEN	WEIR PERIMETER LINEAL FEET
R-3475-A	A	2.7	9.8

Also available with 3 1/2" adjusting frame.

**R-3475-E**  
**Airport Drainage Inlet, Single Ductile Iron Grate**

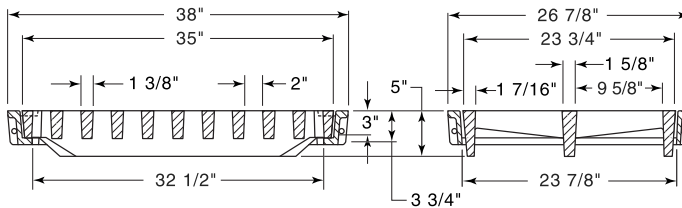

*Grates are bolted to frames.*

CATALOG NUMBER	GRATE TYPE	SQ. FT. OPEN	WEIR PERIMETER LINEAL FEET
R-3475-E	A	2.4	9.8

Each grate has a free open area of approximately 2.4 sq. ft.  
 Features easy-to-install one-piece frame.

■ Note: When specifying/ordering grates, refer to "Choosing the proper inlet grate" on pages 117-118.  
 For a complete listing of FREE OPEN AREAS and WEIR PERIMETERS of all NEENAH grates, refer to pages 306-311.

**R-3475-F**  
**Airport Drainage Inlet, Double Ductile Iron Grate**

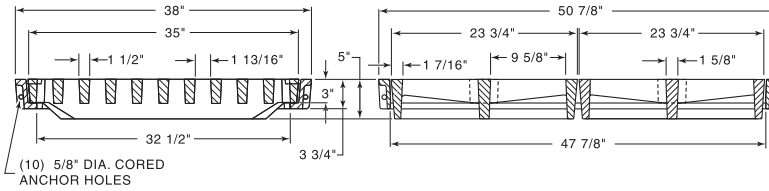

CATALOG NUMBER	GRATE TYPE	SQ. FT. OPEN	WEIR PERIMETER LINEAL FEET
R-3475-F	C	4.8	13.8

Each grate has a free open area of approximately 2.4 sq. ft.  
 Features easy-to-install one-piece frame.



Grates are bolted to frames.

**R-3475-G**  
**Airport Drainage Inlet, Triple Ductile Iron Grate**

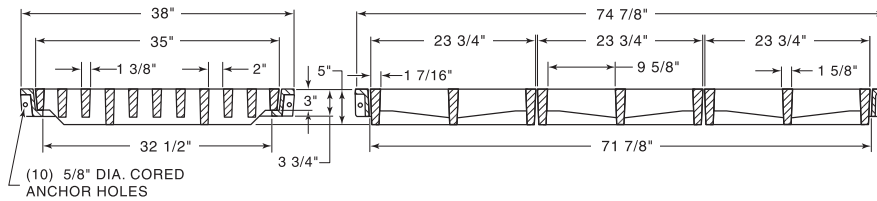

CATALOG NUMBER	GRATE TYPE	SQ. FT. OPEN	WEIR PERIMETER LINEAL FEET
R-3475-G	C	7.2	17.8

Each grate has a free open area of approximately 2.4 sq. ft.  
 Features easy-to-install one-piece frame.

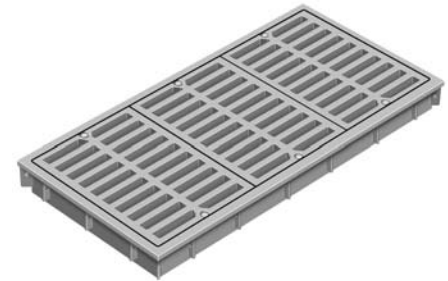

Grates are bolted to frames.

**R-3475-H**  
**Airport Drainage Inlet, Quad Ductile Iron Grate**

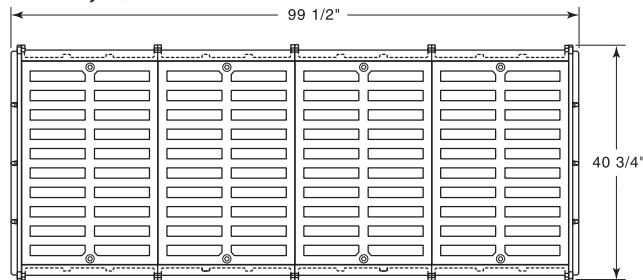

- NOTE:**
- 1-CLEAR OPENING IS 32" x 96"
  - 2-FRAME HEIGHT IS 3 3/4"
  - 3-USE SAME GRATES AS R-3475-G

Each grate has a free open area of approximately 2.4 sq. ft.  
 Frame/Grate units can be combined for longer length runs if specified.

CATALOG NUMBER	GRATE TYPE	SQ. FT. OPEN	WEIR PERIMETER LINEAL FEET
R-3475-H	C	9.6	21.8

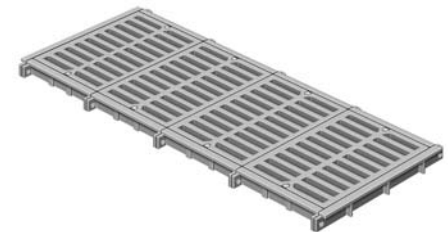

Grates are bolted to frames.

■ Note: When specifying/ordering grates, refer to "Choosing the proper inlet grate" on pages 117-118.  
 For a complete listing of FREE OPEN AREAS and WEIR PERIMETERS of all NEENAH grates, refer to pages 306-311.

**R-3477-A**  
**Airport Drainage Inlet Frame, Double Grate**

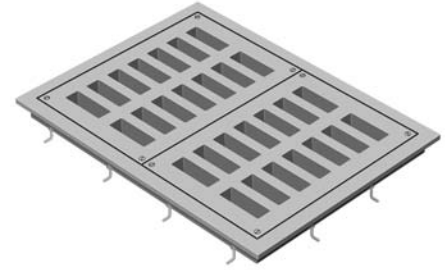
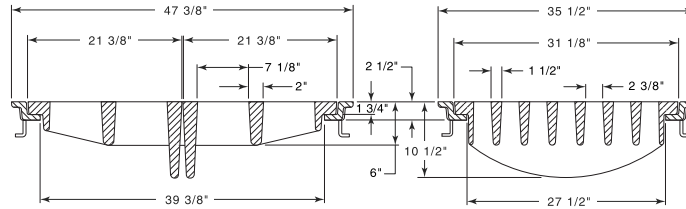

CATALOG NUMBER	GRATE TYPE	SQ. FT. OPEN	WEIR PERIMETER LINEAL FEET
R-3477-A	C	3.3	12.3

Anchors 12" On Center.

Grates are bolted to frames.

**R-3480**  
**Airport Drainage Inlet Frame, Double Grate**

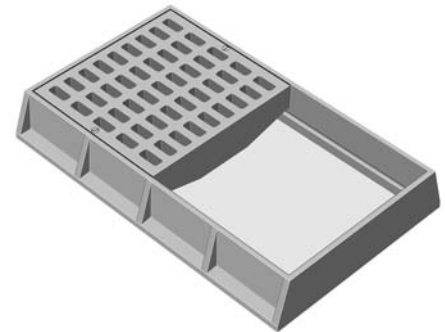
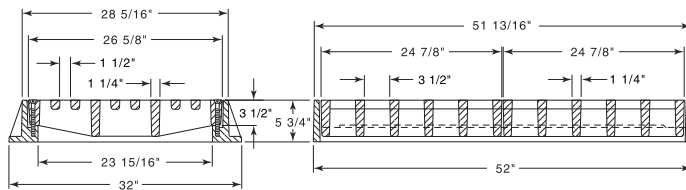

CATALOG NUMBER	GRATE TYPE	SQ. FT. OPEN	WEIR PERIMETER LINEAL FEET
R-3480	C	3.3	12.7

Available with solid Type C cover upon request.

Grates are bolted to frames.

**R-3480-A**  
**Airport Drainage Inlet Frame, Single Grate**

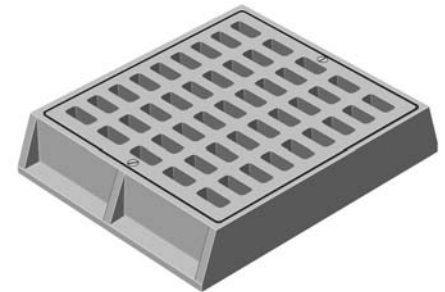
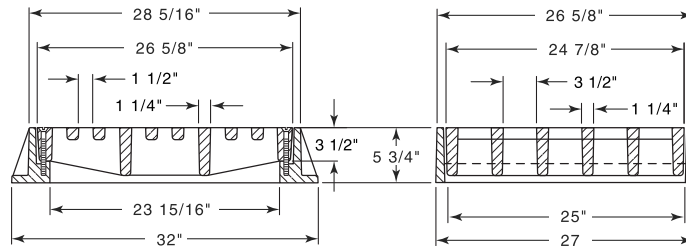

CATALOG NUMBER	GRATE TYPE	SQ. FT. OPEN	WEIR PERIMETER LINEAL FEET
R-3480-A	A	1.6	8.5

Available with solid Type C cover upon request.

Grates are bolted to frames.

**R-3481**  
**Airport Inlet, Double Grate**

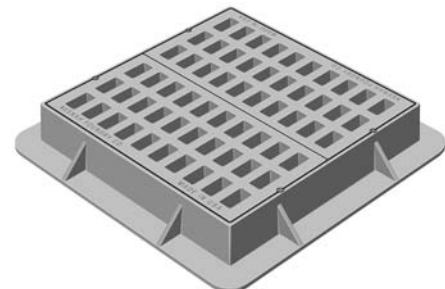
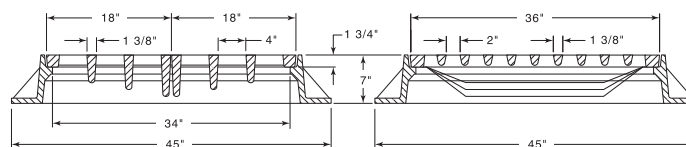

CATALOG NUMBER	GRATE TYPE	SQ. FT. OPEN	WEIR PERIMETER LINEAL FEET
R-3481	C	3.3	12

Grates are bolted to frames.

**R-3485-B**  
**Airport Frame, Solid Lid**

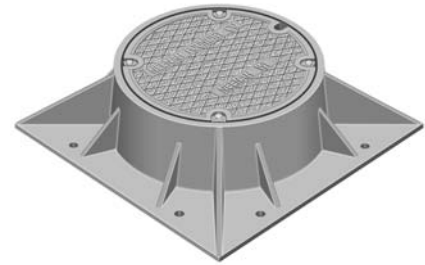
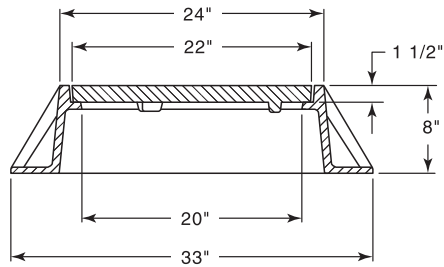

*Lids are bolted to frame.*

**R-3486**  
**Airport Tie-Down Frame, Lid**

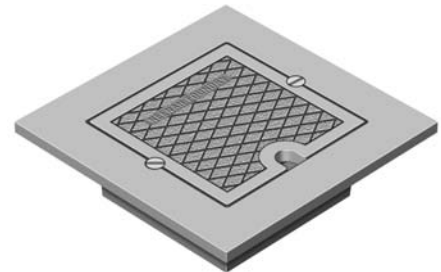
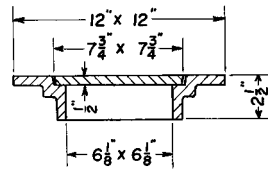

*Lids are bolted to frame.*

Will cover deeply anchored large tie-down eyes for heavy aircraft.  
 Meets FAA 250 psi tire pressure requirement.  
 Due to small size, 100,000 lb. load not applicable.

**R-3487**  
**Airport Inspection Frame, Lid**

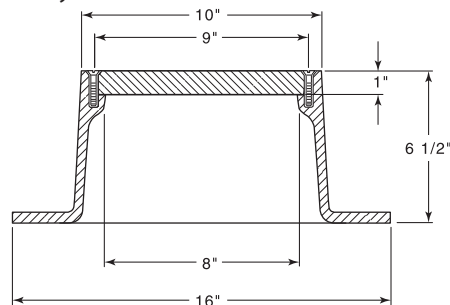

*Lids are bolted to frame.*

Meets FAA 250 psi tire pressure requirement.  
 Due to small size, 100,000 lb. load not applicable.

**R-3488**  
**Airport Control Box Frame, Lid**

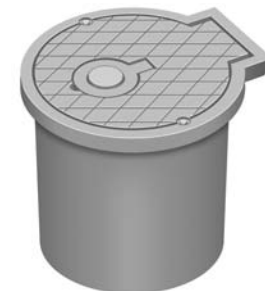
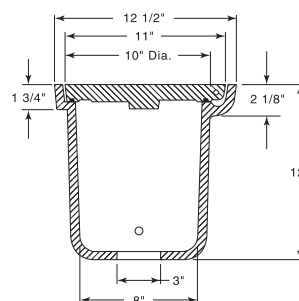

*Lids are bolted to frame.*

Lid furnished standard in Ductile Iron.  
 Polyisoprene gasket is set in machined groove.  
 Lid pivots on stainless steel hinge pin with compression springs.

**R-3489**  
**Airport Fuel Valve Frame, Lid**

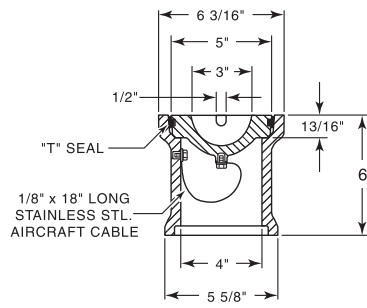

AIRPORT CASTINGS

**R-3490 Series**  
**Airport Mooring Eye**

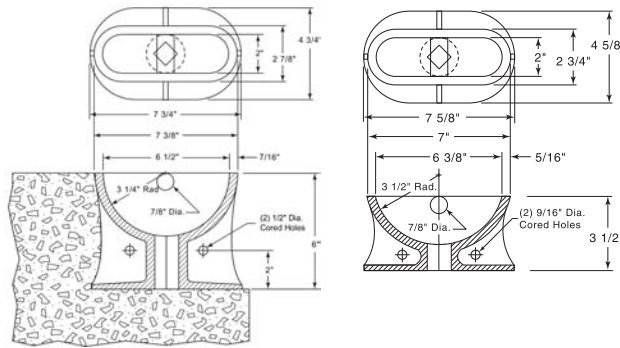

*Illustrating R-3490*

Mooring Eye is placed on subgrade and filled with sand to exclude concrete during the pouring and finishing operation. Sand is easily washed out when paving is completed. Socket opening at bottom of Mooring Eye for wood or metal stake to bring to grade. Square socket design prevents displacement while concrete is being poured and, if required, the hole provides drainage to the subgrade after Mooring Eye is in place. Alternative method of setting is to push the Mooring Eye in position in the wet concrete. Both methods are approved.

When used with bituminous slab, the Mooring Eye should be set in concrete base before paving. Design permits in-flowing of concrete, and the wide base insures proper anchorage. Ribs on the R-3490 and R-3490-A have 1/2" holes for reinforcing rods, if needed. R-3490-B has 1-1/8" cored holes in ribs.

Catalog No.	Height
R-3490	3 1/2
R-3490-A	6
R-3490-B	9

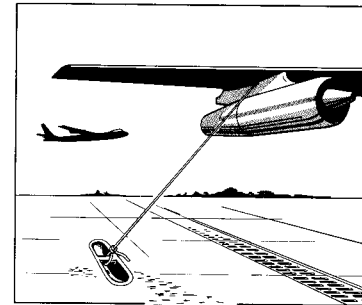
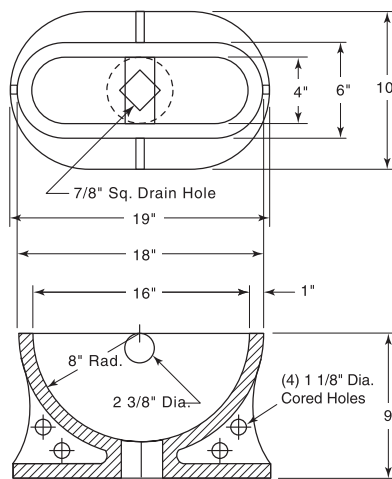

*Illustrating R-3490-B*

■ Note: When specifying/ordering grates, refer to "Choosing the proper inlet grate" on pages 117-118.  
 For a complete listing of FREE OPEN AREAS and WEIR PERIMETERS of all NEENAH grates, refer to pages 306-311.

## R-3491 Series Airport Catch Basin Frame, Grate

CATALOG NUMBER	GRATE TYPE	SQ. FT. OPEN	WEIR PERIMETER LINEAL FEET
R-3491-AG	G	0.9	5.5
R-3491-GG	G	1.6	7.1
R-3491-HG	G	1.9	7.6
R-3491JG	G	2.4	8.5

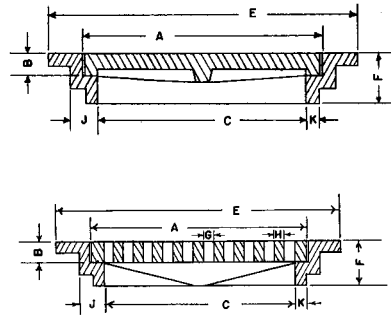

Lids/Grates are bolted to frame.

For Slab Manhole Construction

Catalog No.		Dimensions in inches									
Solid Lid	Open Grate	A	B	C	E	F	G	H	J	K	
R-3491-AL	R-3491-AG *	21	2 1/2	18	27 1/2	5	1 1/4	1	2 7/8	1	
R-3491-GL *	R-3491-GG *	27	2 1/2	24	33 1/2	5	1 1/2	1	2 7/8	1	
R-3491-HL	R-3491-HG	29	1 3/4	27	35	6	1 1/2	1	2 7/8	1	
R-3491-JL	R-3491-JG	32 3/8	2	30	39 1/2	6	1 1/2	1	2 7/8	1	

Frames in gray iron, grates/covers in ductile unless noted otherwise.  
 \* Gray iron grate/cover.

## R-3492 Series Airport Manhole Frame, Lid

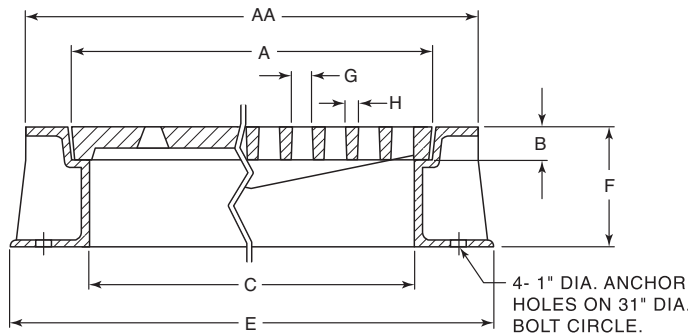

Lids/Grates are bolted to frame.

For Slab or Built-up Manhole Construction

Top and bottom flange provide complete anchorage so frame becomes an integral part of the slab. Can be gasket sealed for watertight application if specified.

Catalog No.		Dimensions in inches									Lid/Grate Material
Solid Lid	Open Grate	A	AA	B	C	E	F	G	H		
R-3492	R-3492-1	27	33 1/2	2 1/2	24	36	9	1 1/2	1	Gray Iron	
R-3492-A	R-3492-A1	32 3/8	39 1/2	2	30	42	9	1 1/2	1	Ductile Iron	

CATALOG NUMBER	GRATE TYPE	SQ. FT. OPEN	WEIR PERIMETER LINEAL FEET
R-3492-1	G	1.6	7.1
R-3492-A1	G	2.4	8.5

AIRPORT CASTINGS 4

■ Note: When specifying/ordering grates, refer to "Choosing the proper inlet grate" on pages 117-118.  
 For a complete listing of FREE OPEN AREAS and WEIR PERIMETERS of all NEENAH grates, refer to pages 306-311.

**R-3492-B**  
**Airport Manhole Frame, Solid Lid**

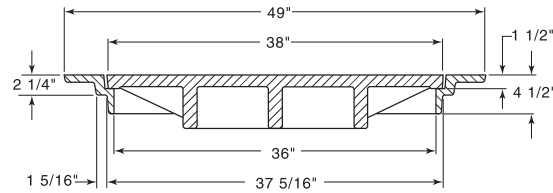

*Lids are bolted to frame.*

For Slab Manhole Construction

**R-3492-BG**  
**Airport Manhole Frame, Ductile Iron Grate**

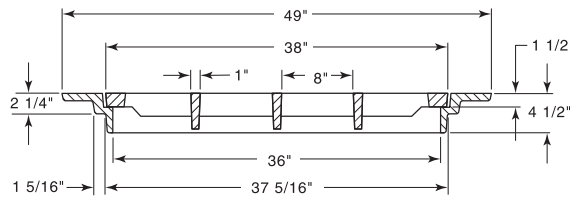

*Grates are bolted to frames.*

CATALOG NUMBER	GRATE TYPE	SQ. FT. OPEN	WEIR PERIMETER LINEAL FEET
R-3492-BG	G	2.6	9.9

For Slab Manhole Construction

**R-3492-C**  
**Airport Manhole Frame, Solid Lid**

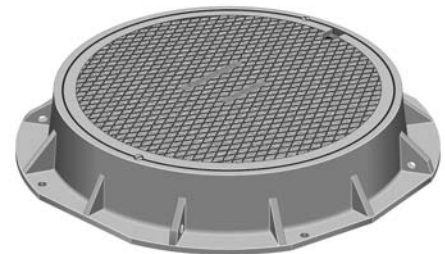
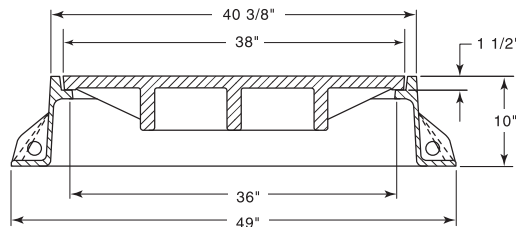

*Lids are bolted to frame.*

For Built-up Manhole Construction  
 Available with square base flange, see R-1795-M.

**R-3492-CG**  
**Airport Manhole Frame, Ductile Iron Grate**

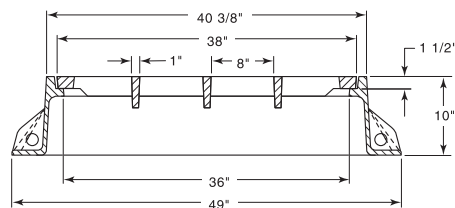

*Grates are bolted to frames.*

CATALOG NUMBER	GRATE TYPE	SQ. FT. OPEN	WEIR PERIMETER LINEAL FEET
R-3492-CG	G	2.6	9.9

For Built-up Manhole Construction  
 Available with square base flange, see R-1795-M.

■ Note: When specifying/ordering grates, refer to "Choosing the proper inlet grate" on pages 117-118.  
 For a complete listing of FREE OPEN AREAS and WEIR PERIMETERS of all NEENAH grates, refer to pages 306-311.

**R-3493-A**  
**Airport Manhole Frame, Solid Lid**

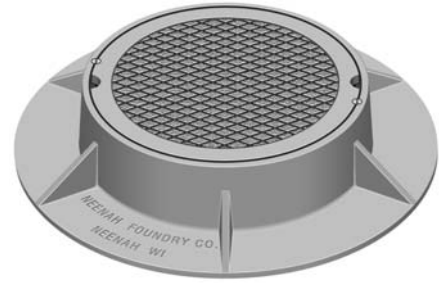
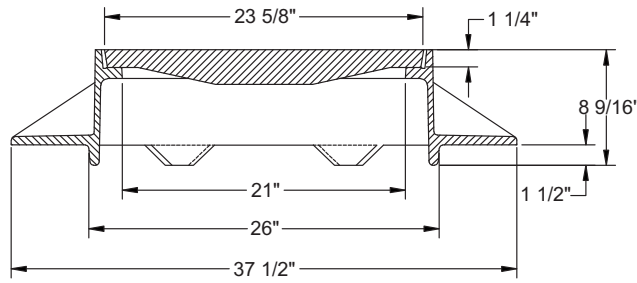

*Lids are bolted to frame.*

For Built-up Manhole Construction.  
 Frame ring consists of 6 equally spaced lugs.

**R-3493-C**  
**Airport Manhole Frame, Ductile Iron Grate**

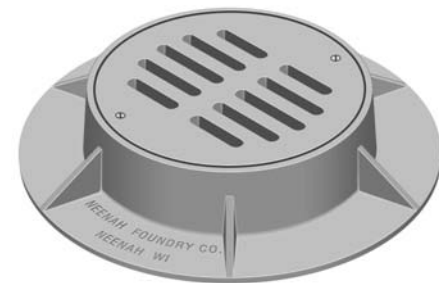
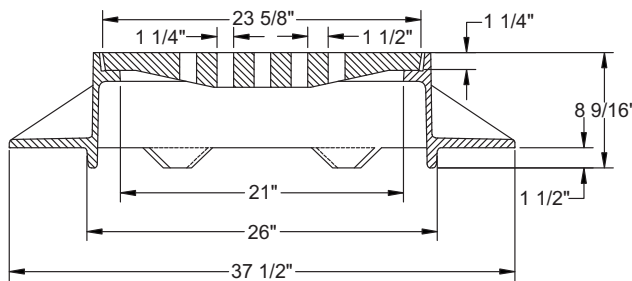

*Grates are bolted to frames.*

CATALOG NUMBER	GRATE TYPE	SQ. FT. OPEN	WEIR PERIMETER LINEAL FEET
R-3493-C	G	0.6	6.2

For Built-up Manhole Construction.  
 Frame ring consists of 6 equally spaced lugs.

**R-3494**  
**Airport Hinged Frame, Ductile Iron 4-piece Lid**

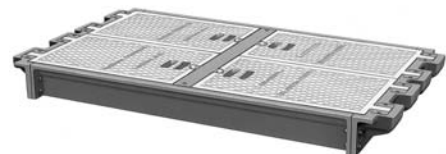
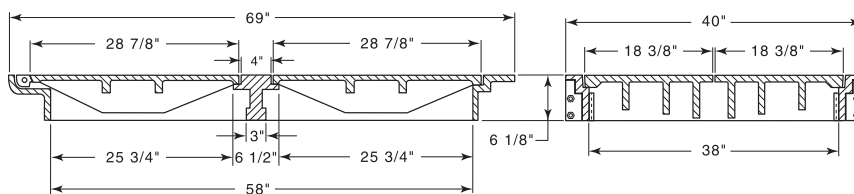

*Lids are bolted to frame.*

For Built-up Manhole Construction

**R-3495**  
**Airport Manhole Frame, Ductile Iron Lid, Bolted/Gasket Sealed**

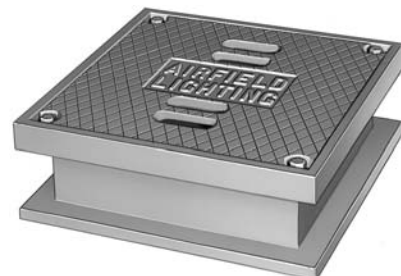
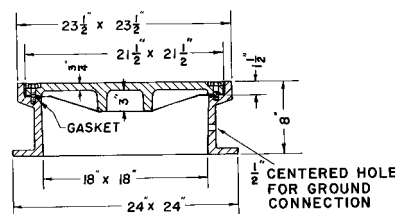

*Lids are bolted to frame.*

For Slab or Built-up Manhole Construction

AIRPORT CASTINGS 4

■ Note: When specifying/ordering grates, refer to "Choosing the proper inlet grate" on pages 117-118.  
 For a complete listing of FREE OPEN AREAS and WEIR PERIMETERS of all NEENAH grates, refer to pages 306-311.

**R-3497-A**  
**Airport Manhole Frame, Lid**

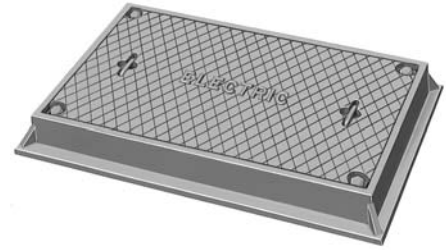
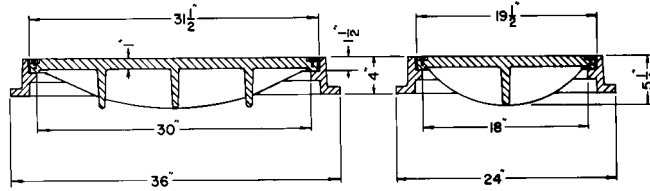

Lids are bolted to frame.

For Built-up Manhole Construction

**R-3498 Spring-Assist Hatch Series**  
**Gray Iron Frames with Ductile Iron Lids**  
**Proof Load Tested to 200,000#**  
**Patent #7216459**

CATALOG NUMBER	GRATE TYPE	SQ. FT. OPEN	WEIR PERIMETER LINEAL FEET
R-3498-K2GS	A or C	1.5	8.6
R-3498-P2GS	A or C	2.1	10.5
R-3498-R2GS	A or C	3.0	12.8
R-3498-R3GS	A	6.0	19.0

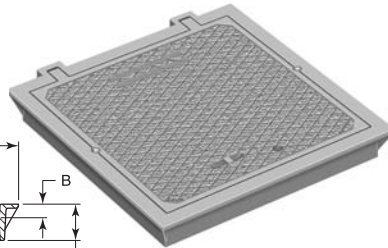
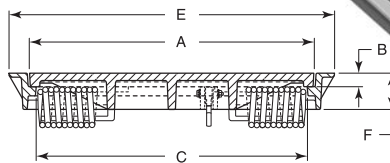

Illustrating R-3498-P2S

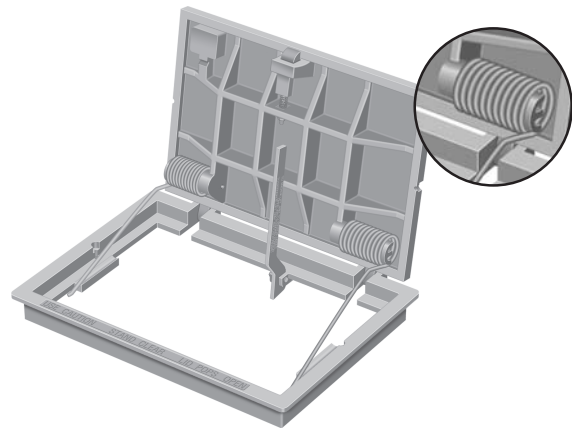

Illustrating R-3498-J3S

Castings strong enough to handle severe loads are inherently heavy. Lifting these heavy lids/grates to gain access to sub-ground utilities has been an issue for maintenance crews. Lifting these heavy covers requires multiple personnel and lifting equipment. With Neenah's Spring-Assist Hatches, a single maintenance worker can quickly open the lid, secure it in the upright position with Neenah's hold-open device and perform the necessary work.

**FEATURES UNIQUE to the NEENAH R-3498 SERIES:**

- Lid mounted springs move out of the free open area, exposing the free opening.
- Spring position allows more spring rotation, thus more spring power.
- Slam-latch enables opening and closing with ease. Simply pop the lid open and slam it shut.
- Self-contained frame, lid and spring assembly pushes on itself, not external wall structures.
- Easy spring removal and replacement.
- Neenah's Perma-Grip non-skid surface.
- Optional tool-less latch release for fire hydrant or quick access applications.

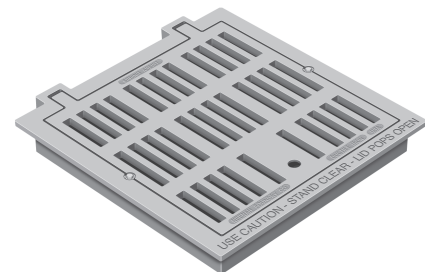

Illustrating R-3498-K2GS

Catalog No.		Dimensions in inches					Lid
Solid Lid	Open Grate	A	B	C	E	F	Weight
<b>Square</b>							
R-3498-K2S	R-3498-K2GS	25 3/4 x 25 3/4	1 1/2	24 x 24	30 x 30	4	251#
R-3498-P2S	R-3498-P2GS	32 x 32	1 1/2	30 x 30	36 x 36	4	358#
R-3498-R2S	R-3498-R2GS	38 3/8 x 38 3/8	1 1/2	36 x 36	42 x 42	4	471#
R-3498-T2S *		50 x 50	1 1/2	48 x 48	56 x 56	4	571# *

Catalog No.		Dimensions in inches					Lid
Solid Lid	Open Grate	A	B	C	E	F	Weight
<b>Rectangular</b>							
R-3498-J3S	-	25 7/8 x 37 7/8	1 1/2	36 x 24	42 x 30	4	340#
R-3498-R3S **	R-3498-R3GS ***	76 9/16 x 38 3/8	1 1/2	74 3/16 x 36	80 3/16 x 42	4	471#

\* 2-piece cover  
 \*\* with support bar

Optional threaded hole in frame for Grounding Strap - specify if required.

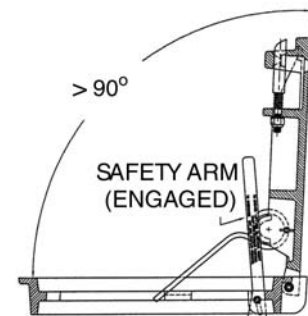

■ Note: When specifying/ordering grates, refer to "Choosing the proper inlet grate" on pages 117-118.  
 For a complete listing of FREE OPEN AREAS and WEIR PERIMETERS of all NEENAH grates, refer to pages 306-311.

**R-3499**  
**Airport Utility Frame, Ductile Iron Cover**

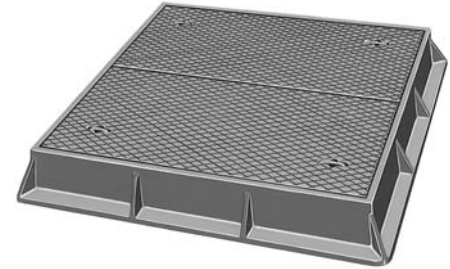
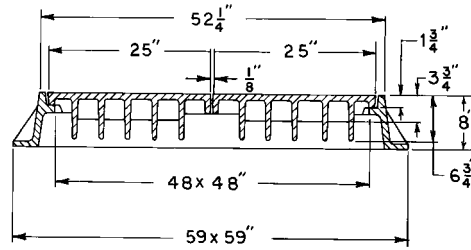

Lids are bolted to frame.

**R-3599-B**  
**Airport Slotted Vane Drain**

CATALOG NUMBER	GRATE TYPE	SQ. FT. OPEN	WEIR PERIMETER LINEAL FEET
R-3599-B	L	0.2	2 per ft.

NEENAH's Cast Iron Slotted Vane Drain offers ease of installation along with the superior vaned configuration to capture previously unexpected quantities of water when placed perpendicular to the flow. Installation is accomplished by sawing a slot in the top of conventional PVC pipe, placing the pipe on grade, installing the Cast Iron Slotted Vane Drain in place and pouring the concrete. When used in conjunction with a vane grate inlet, virtually all the surface water which would normally bypass the catch basin, can be captured. This permits the spacing between inlets to be increased. An additional benefit is the added safety factor obtained should the catch basin be plugged or covered with snow. The unit may also be installed wherever sheet flow capture is required. Slotted vane drains shown are allowed per FAA Advisory Circular AC 150/5370-10A Change 11. For installation information, refer to **R-3599-A**.

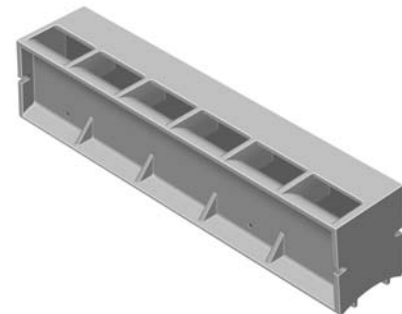
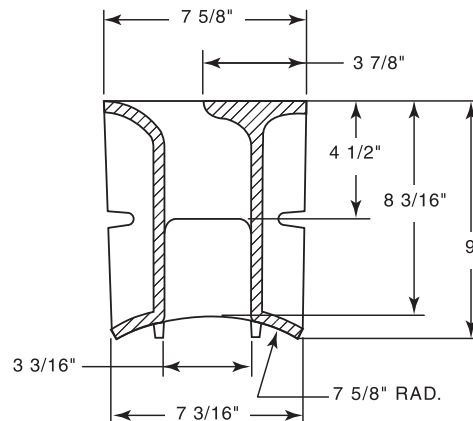

■ Note: When specifying/ordering grates, refer to "Choosing the proper inlet grate" on pages 117-118.  
 For a complete listing of FREE OPEN AREAS and WEIR PERIMETERS of all NEENAH grates, refer to pages 306-311.

## R-4990 Airport, Port & Heavy Industrial Series Bolted Trench for Extra Heavy Duty Applications

These trench drains are capable of supporting the heavy wheel loads of today's commercial environments. For larger trench widths or greater loading requirements, please contact our Product Engineering Department.  
 Grates are bolted to gray iron frames.

Suitable for aircraft loading per AC150/5320-6D.  
 Refer to R-4990 Series for installation information.

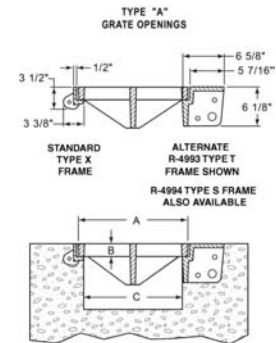
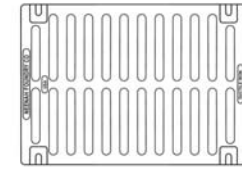

Catalog No.	Dimensions in inches			Grate/Cover Material
	A	B	C	
R-4990-AA	8	2	6	Gray Iron Class 35
R-4990-BA	10	2	8	Gray Iron Class 35
R-4990-CA	12	2	10	Ductile Iron
R-4990-DA * **	14	2	12	Ductile Iron
R-4990-EA *	17	2	15	Ductile Iron
R-4990-FA *	20	2	18	Ductile Iron
R-4990-HA *	26	2	24	Ductile Iron
R-4990-KA2 *	34	2	31	Ductile Iron
R-4990-OA *	51	2	48	Ductile Iron

\* Type D solid cover available.  
 \*\* Type C grate available.

Ductile Iron furnished in Grade 80-55-06.

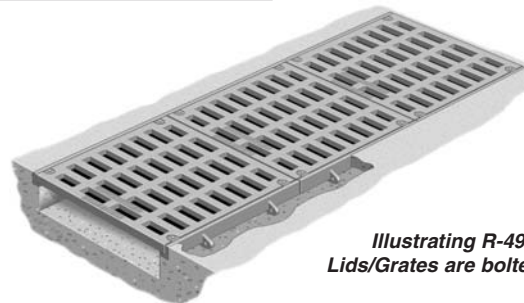

Illustrating R-4990-HA.  
 Lids/Grates are bolted to frame.

## R-4993 and R-4994 Superior Durability Frame Series for Airports, Ports, Industrial Sites and Roads

### Superior Duty Frames

Designers have the option to utilize either of these new frames in locations where it is deemed that traditional angle frames could break loose from concrete due to extraordinary conditions. A few examples of such conditions are: braking forces of ultra heavy vehicles; torsional forces due to turning aircraft and container port vehicles; heavy airfield and industrial applications; highway tunnels; certain highway applications.

Neenah offers two frame choices each with its own unique benefits. For complete information, please refer to the R-4993 and R-4994 Series in the Trench section of our catalog.

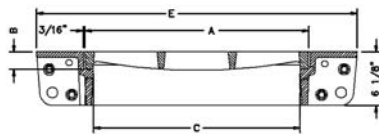

Illustrating R-4993 Type T Frame

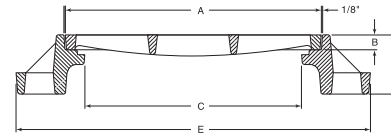

Illustrating R-4994 Type S Frame.

Type T Catalog No.	Type S Catalog No.	Dimensions in inches						Type A	Type C	Type D
		A	B	Type T		Type S				
				C	E	C	E			
R-4993-AAB	R-4994-AAB	8	2	6	19 1/4	4	18	x		
R-4993-BAB	R-4994-BAB	10	2	8	21 1/4	6	20	x		
R-4993-CAB	R-4994-CAB	12	2	10	23 1/4	8	22	x		
R-4993-DAB	R-4994-DAB	14	2	12	25 1/4	10	24	x	x	x
R-4993-EAB	R-4994-EAB	17	2	15	28 1/4	13	27	x		x
R-4993-FAB	R-4994-FAB	20	2	18	31 1/4	16	30	x		x
R-4993-HAB	R-4994-HAB	26	2	24	37 1/4	22	36	x		x
R-4993-KAB	R-4994-KAB	34	2	32	45 1/4	30	44	x		x
R-4993-OAB	R-4994-OAB	51	2	49	62 1/4	47	61	x		x

x - Indicates availability

■ Note: When specifying/ordering grates, refer to “Choosing the proper inlet grate” on pages 117-118.  
For a complete listing of FREE OPEN AREAS and WEIR PERIMETERS of all NEENAH grates, refer to pages 306-311.

## R-4994 LiftMate Series Superior Durability Frames for Airports, Ports, Industrial Sites and Roads

### Superior Duty LiftMate Frames

Neenah’s new LiftMate Hinge System is now being applied to our R-4994 Type S Frame trench series. These trench drains are capable of supporting the heavy wheel loads of today’s commercial environments. Please see page 13 for additional LiftMate information and contact our office regarding your project needs. Visit [www.neenahfoundry.com](http://www.neenahfoundry.com) for more information on the LiftMate series.

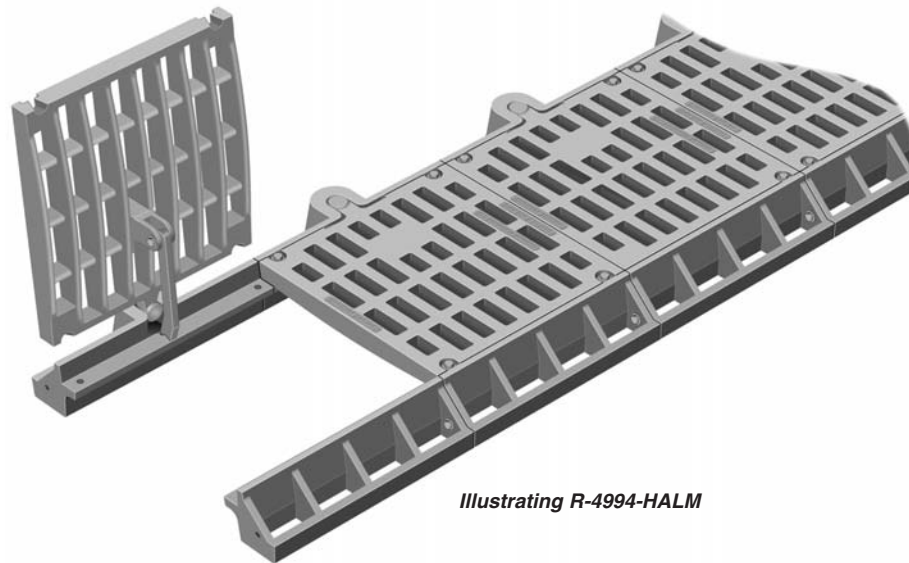
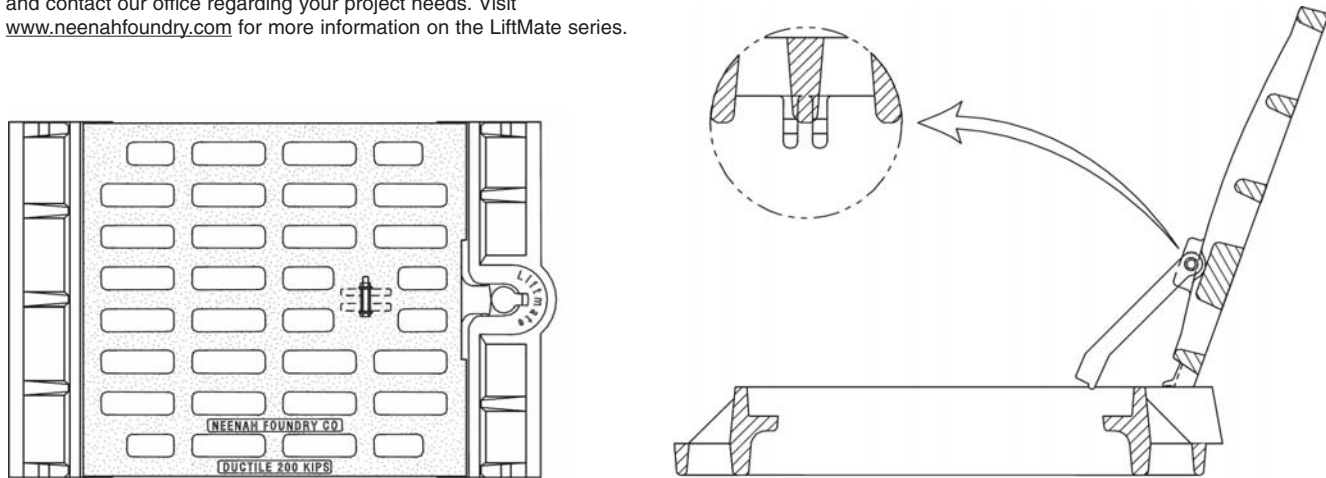

Illustrating R-4994-HALM