

NEENAH

FOUNDRY COMPANY

Experience, Innovation, Service

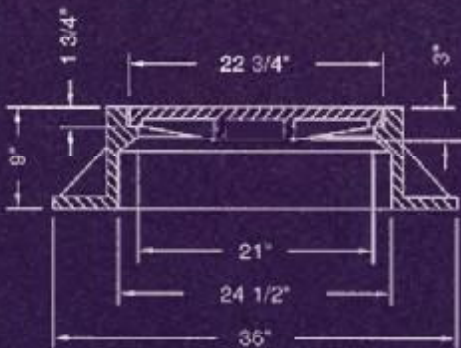

WEIGHT: FRAME 370#
LID 146#
PROOF LOAD 93,600#
CIRCA 1944

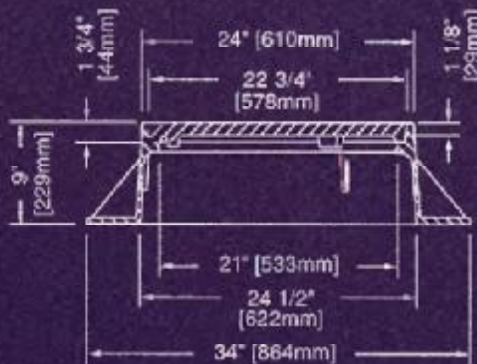

WEIGHT: FRAME 162#
LID 125#
PROOF LOAD 105,300#
1994

IT'S AMAZING! The frame and lid on the right are 45% lighter than the combination on the left ... yet they exceed AASHTO performance requirements by more than 100%.

MODERNIZED CASTINGS FOR TOMORROW'S WORLD

PROGRESS

Horse-drawn plows have given way to diesel tractors ... gravel roads have expanded into multi-lane interstate highways ... gas-guzzlers of the '50s have yielded the road to today's more efficient and reliable automobiles ... and the heavy construction castings designs of years past are being replaced by new lighter and stronger designs thanks to innovative foundry technology.

BREAKTHROUGHS IN CASTING CONCEPTS

Modern Platen Lids

As our engineers have known for some time, Platen (plate-shaped) lids are improved manhole covers which are significantly stronger than ribbed lids.

Advantages of the modern Platen lid include:

- Increased ultimate load
- Increased deflection
- Increased energy absorption
- Increased efficiency
- Decreased weight
- Easier to handle

Do modern Platen lids do the job? We've sold more than 100,000 Platen lids across the nation over the last decade. Hundreds of specifying engineers, municipalities and governmental bodies have adopted a Platen lid design and are now specifying it on their plans.

Even though a Platen lid generally weighs about 80% of the standard ribbed lid, it's no performance light-weight. For example, the R-1740-B Platen lid shown below is over 50 pounds lighter, yet:

- Has a load capacity 45% greater than the standard ribbed lid
- Has an impact resistance 200% greater than the standard ribbed lid

And Platen lids are interchangeable with standard lids and frames.

Modern Lighter-weight Frames

Manhole frames have an inherently strong shape. In the past, metal sections had to be thicker because foundry molding equipment was imprecise. To compensate, generous tolerances were required to ensure minimum section thickness.

Today's molding machines are capable of holding extremely tight tolerances, allowing specifiers to reduce weights and section thicknesses.

Technology now allows us to take full advantage of the frame's inherently strong shape.

Modern frames are significantly reduced in weight and section thickness, without a reduction in relevant performance characteristics.

Lighter frames are viable because gray iron is three times stronger in compression than in tension. The lighter frames are still so substantial that, under load testing, an iron lid or steel grate will fail well before damage occurs to the frame.

Proof load testing has been done on modernized frames with as little as 6mm wall thicknesses to over 450,000 pounds without failure (R-1642, 7" high).

Modern frames can be produced in shapes that are stackable. This makes them much safer to handle and allows them to be shipped more economically because heavy shipping pallets are not required.

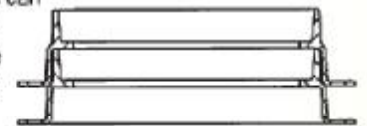

As with Platen lids, modern frames are interchangeable with previous heavier versions.

R-1740-B WITH PLATEN LID AND LIGHTER WEIGHT FRAME

	Old Unit	New Unit	Improvement
Frame Weight	357 lbs	216 lbs	-40%
Lid Weight	327 lbs	273 lbs	-17%
Unit Weight	684 lbs	489 lbs	-28%
Ultimate Load Capacity	69,200 lbs	100,700 lbs	+45%
Impact Resistance	550 ft-lbs	1640 ft-lbs	+200%

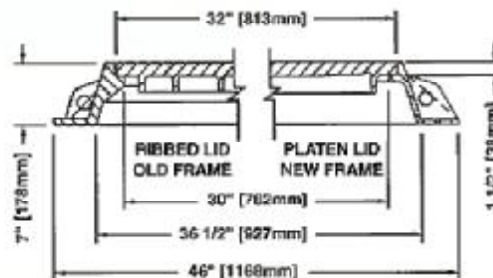

Cross section view of old unit on left and new unit on right.



A RESEARCH PROGRAM BASED ON FULL-SCALE DESTRUCTIVE TESTING TO REACH THE TRUE LIMITS OF CASTING PERFORMANCE

Neenah Foundry recommends the proof load criteria of AASHTO M-306 as the proper specification to be used in evaluating construction castings.

- Section 1.1 of this specification explains its scope: "This specification is applicable to frames, grates, rings, and covers for inlets, manholes, and other structures for civil engineering use where tensile strength is a major consideration."
- Section 3.1 calls for castings to be produced from class 35-B iron per AASHTO M-105.
- Section 7.1 describes a 40,000-pound proof load test that can be used to evaluate actual performance. Loads of 40,000 pounds represent a safety factor of 2 1/2 over HS-20 wheel loads of 16,000 pounds.



August 24, 1994

Illinois Department of Transportation
126 East Ash Street
Springfield IL 62766

Gentlemen:

We have conducted proof load testing of the components 1015-2000 frame and 1015-5000 lid. The proof load test was conducted per Federal specification 88-F-621 and AASHTO specification M-306. Both specifications require a 9 x 9 inch contact area centered on the lid. 88-F-621 requires a load of 20,000 pounds and M-306 requires a load of 40,000 pounds. The lid failed at 109,200 pounds.

A second test was conducted to prove the strength of the frame. A new lid was placed in the frame with a crossed lid placed upside-down on top and centered on the new lid. On top of the second lid was placed a 10 x 10 inch contact area with additional spacers. A load of 200,000 pounds was applied to this setup without failure of the frame or any other component. The load was held for a period of one minute.

An ASTM A49 class B test bar representing the lid had a tensile strength of 36,300 psi.

The tests described above have been videotaped and copies can be made available for your review.

Yours truly,

Steve Akkila
Steve Akkila, P.E.
Manager - Product Engineering
Construction Division

dja

SALES OFFICES AND DISTRIBUTION YARDS & PRODUCTION LINES THROUGHOUT THE U.S.A.
A WELTON CORPORATION COMPANY



UNIVERSITY OF WISCONSIN - MADISON
Structures and Materials Testing Laboratory
Professor Service M. Crisner, Director
2314 Engineering Hall, 1415 Engineering Drive, Madison, WI 53706
Telephone: (608) 265-6714 Fax: (608) 265-8214

TEST CERTIFICATE

DATE RECEIVED:	NEENAH FOUNDRY CO.	INVOICE:	DATE:	TIME:	TESTER:
TIME:	10/15/94	INVOICE:	10/15/94	TIME:	11:00 AM
PROJECT:	N/A				

TEST DESCRIPTION

1 EACH MANHOLE CASTING WAS TESTED UNDER COMPRESSIVE LOADS UNTIL THE BOARDING SURFACE THROUGH THE CENTER OF THE SURFACE SUBJECTED THE LOAD WAS APPLIED AT RATES OF 200 LBS PER MINUTE UNTIL FAILURE.
COMPRESSIVE FAILURE OCCURRED @ 590,000 LBS.
LOAD HELD FOR 15 MINUTES WAS TESTED AT AN X-Y PLOTTING.

TEST IDENTIFICATION	INFER	MODEL NO.	SER	GW NO.	CALIBRATION
1 MILLIPLY POUND FORCE TESTING MACHINE	GRANTING MACHINE	700078	07550	34773	02/20/94
STRUT	NEWTON SCALE	7030A	2941AD7719	530319	@ 7500 of 10N
LOADS	NEWTON SCALE	1000 25	710341	37A	@ 2000 of 10N
DIGITAL VOLT/METER (5 DIGIT)	ELITE	2941A	4132258	206464	1/5/93

TESTED BY: *W. D. Duff*
DATE: 10/15/94
TESTER: *Steve M. Crisner*
TITLE: MGR, CIVIL

Modernized frame tested to destruction by independent testing laboratory. (See resulting report above.) Lighter weight frame did not fail until 590,000 pounds of compressive pressure was applied.





BENEFITS OF MODERNIZED CASTINGS

- Less weight results in less costly shipping. Neatly stackable frames are safer to handle and do not require costly shipping pallets.
- Specifiers can enhance their designs recognizing the need to control costs.
- Lighter castings require less raw material to manufacture and are a more responsible use of resources.
- Lighter castings are easier on workers' backs. This can translate into decreased costs for worker's compensation insurance and improved employee productivity.
- Modernized castings are stronger as well as lighter. Load capacity of castings can be confirmed by empirical data per AASHTO M-306.
- New, lighter-weight frames and covers are interchangeable with existing standards.



All Neenah Castings are manufactured from recycled materials including automobile bodies and other collected scrap irons.

NEENAH 
FOUNDRY COMPANY

Experience, Innovation, Service

2121 BROOKS AVENUE, P.O. BOX 729
NEENAH, WI 54957
TELEPHONE (414)725-7000
FAX (414)729-3661

MODERNIZED CASTINGS CONCEPTS FOR THE FUTURE